

RDS-300X

4-Channel High Performance DDS Module



Features

- 4 Independent DDS Channels
- Direct Digital Synthesis up to 120 MHz
- Onboard I/Q Up Conversion from 700 MHz to 2500 MHz
- Integrated TCU for realtime control
- Calibration circuit for maximum image rejection and minimum LO leakage
- 6U x 160 mm VME Module
- 48-bit Frequency Resolution
- 14-bit Phase Resolution
- 12-bit Amplitude Resolution
- CW, FSK, BPSK, PSK, CHIRP, and AM
- Offers front panel serial port control

General Description

The RDS300X-4 offers four 300 MHz Direct Digital Synthesis (DDS) channels on a single 6U VME Module. All channels are independently controlled and are matched for minimal channel to channel skew. Each channel consists of 2 DDS chips, a LPF, a differential I/Q modulator, an amplifier and an external independent LO input for signal up-conversion. The DDS chips can generate outputs up to 120 MHz which are then up-converted to a maximum of 2500 MHz via the IQ Modulator.

The RDS300X-4 has a calibration circuit which further enhances the high performance of the DDS chips and I/Q modulators. Each channel can be switched into the calibration circuit and be dynamically calibrated to achieve minimum LO leakage and maximum image rejection. These offset parameters are stored in an EEPROM which the FPGA uses to adjust to the real-time DDS controls for optimum performance.

The RDS300X-4 can receive controls through the VME P2 interface, or from the front panel serial port or VMEbus interface via the on board timing and control unit (TCU). All sources send controls to the Xilinx Virtex-II FPGA, which decodes and formats the messages for the DDS chips. The RDS300X-4 has its own TCU integrated onto it for a single board solution. The heart of the TCU is a Texas Instruments TMS320C6416 720 MHz DSP. It is capable of scheduling complicated timing signals in real-time. For more information on the TCU functionality, visit our website at www.ewa.rss.com.

RDS-300X 4-Channel High Performance DDS Module

Block Diagram

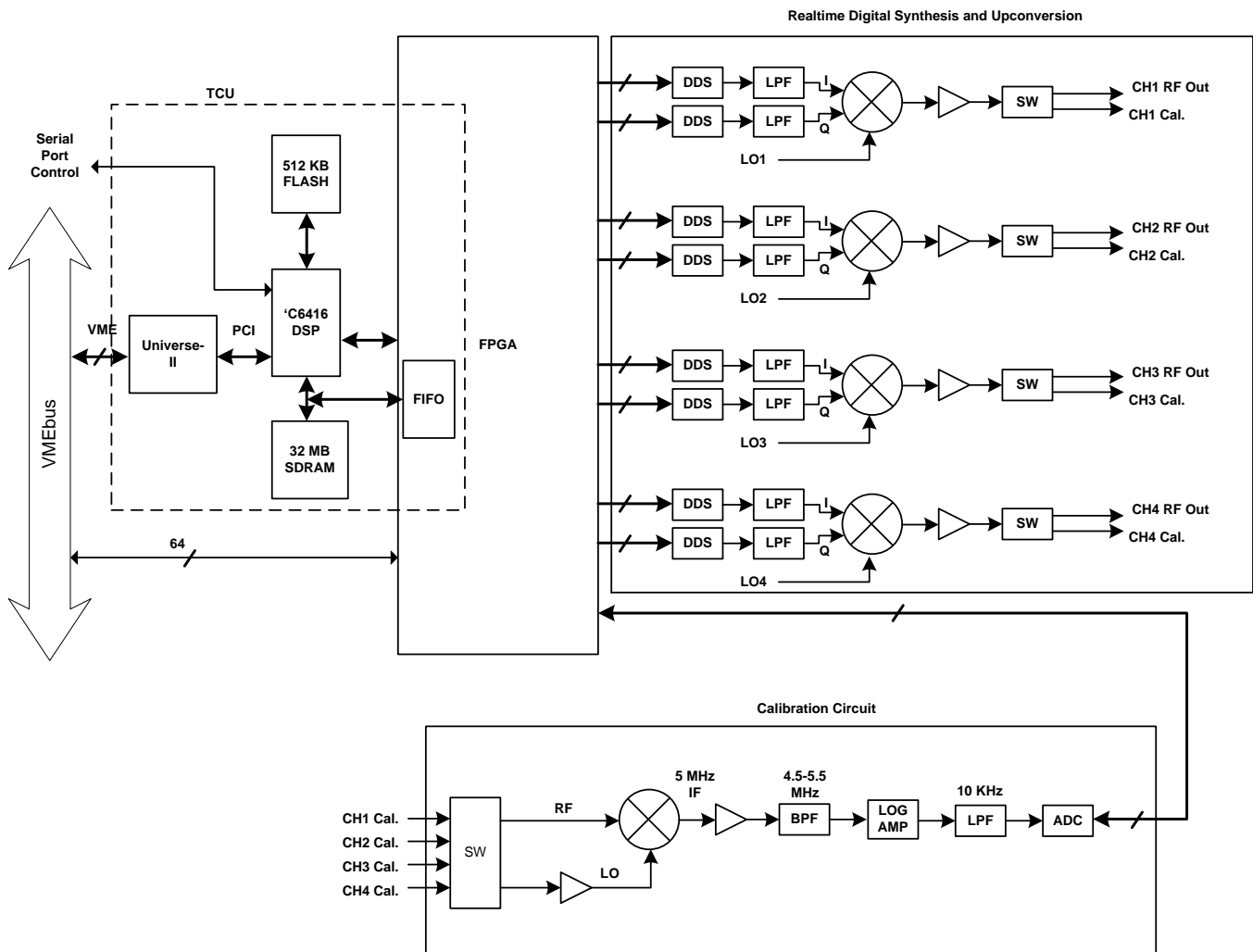

Applications

The RDS300X-4 was developed for use as a real-time waveform generator in a multi-channel radar system. The RDS300X-4 can provide clocks, pulse modulated waveforms, and frequency-hopped waveforms for realtime applications. It is also an excellent solution for test beds requiring multiple IF synthesized signals. Specifically, the RDS300X-4 is capable of generating CW, FSK, BPSK, PSK, CHIRP, and AM waveforms.